



## PEANUT SHELLING MACHINE USING A PETROL ENGINE

William Laia, Nani Sri Rezeki <sup>2</sup>

Universitas Audi Indonesia <sup>1</sup>

Universitas Darma Agung <sup>2</sup>

E-mail: [williamlaia4512@gmail.com](mailto:williamlaia4512@gmail.com) <sup>1</sup>, [srirezekinani@gmail.com](mailto:srirezekinani@gmail.com) <sup>2</sup>

### Info Artikel

Masuk:05-05-2025

Diterima:07-06-2025

Terbit:28-07-2025

**Keywords:** *peanuts, shelling eye, axle, transmission, power*

### Abstract

This study discusses a peanut shelling machine driven by a gasoline-engineered motor. In Indonesia, many processed peanut products require peanuts as a component, such as salted peanuts, peanut oil, peanut paste, peanut tofu, and others. Manual peanut shelling is usually inefficient and time-consuming. Therefore, with this machine, which can automatically peel peanuts, it will greatly help save time and increase production capacity. Based on planning calculations for the planned components, the following data was obtained: Gasoline engine used = 5.5Hp, Pad = 6005, Belt length to peeler = 65 inches, Belt length to blower = 25 inches, Diameter pulley blower = 4 inches, Pulley diameter peeler = 11 inches, Diameter pulley driver = 2 inches. After analyzing the production/manufacturing costs of this machine, the price for manufacturing 1 peanut peeling machine was Rp4,019,372.24.

## 1. INTRODUCTION

Peanuts (*Arachis hypogaea* L.) are cultivated legumes in the Fabaceae family and are the second most important crop in Indonesia after soybeans. Peanuts are a crucial legume crop for food production and have high economic value, making them a popular food crop and also an industrial commodity. Peanuts are a highly valuable agribusiness commodity and a key source of protein in the Indonesian diet (Gafur, 2013).

Peanuts are usually peeled after they are completely dry, ensuring they are of good quality and prevent rot. While the manual method of peeling peanuts one by one by hand is easy, simple, and relatively inexpensive, it can result in swelling of the thumb and index finger.

And at this time, there are still some farmers and business owners who produce peanuts who still use manually driven machines, usually after using a manual peanut peeling machine the body will feel sore, especially in the arms, waist, and back. Seeing the negative impacts of the process of peeling peanuts with the manual method and by using a manually driven machine, it can hinder the work time in peeling peanuts so that the process becomes less efficient and results in less than optimal production.

## 2. LITERATURE REVIEW

In design, it's crucial to consider the fundamentals of raw material selection. When selecting materials, the material, shape, function, and requirements of the machine parts are crucial. These factors are closely related to the material's properties, which influence the safety and durability of the designed tool.

The materials chosen must also be readily available to avoid delays in sourcing them during the manufacturing process. When selecting materials, it's also important to ensure they



offer more advantages than disadvantages. The machine should be as simple as possible, easy to operate, low on repair and maintenance costs, yet deliver satisfactory results with minimal maintenance. Furthermore, the materials used should be reasonably priced.

In this machine there are main parts consisting of:

1. Gasoline Motorbike

A gasoline engine is a power generating machine that converts gasoline fuel into heat energy and ultimately into mechanical energy.

2. Belt and Pulley

Belts and pulleys are a pair of machine elements used to transmit power from one shaft to another. In the machine being designed, belts and pulleys are used to transmit power from the motor to the peanut shelling shaft. The selection of belts and pulleys is crucial to avoid loss of transmitted power. Therefore, the choice of belts and pulleys significantly affects the power that can be transmitted by the belt.

3. Axis

A shaft is a circular metal rod that functions to transfer rotation or support a load with or without transmitting power.

4. Bearings

Bearings are machine elements used to support load shafts, ensuring safe, smooth, and durable rotation or reciprocating motion. Bearings must be robust to allow the shaft or other machine elements to function properly. If the bearings fail, the entire system's performance will suffer or even cease to function properly.

Apart from the main parts, this machine also has supporting parts, the supporting parts in question are:

1. Engine Frame

The engine frame is the part of the engine that supports or supports other engine components. The size and strength of the frame must be considered, as it must meet the requirements of both the support and the machine.

2. Bolts and Nuts

Bolts and nuts function as fasteners for the mounting on the drive motor but apart from that, they function to bind the shaft to the pulley.

3. L-profile iron

L-shaped iron, or angle iron, is iron formed to form a  $90^\circ$  angle. Its cross-section resembles the letter L, similar to a right triangle, except that one side is not closed. Angle iron is generally produced in 6-meter lengths. There is also what is called perforated angle iron, which is angle iron with holes of equal size along its sides.

### **3. IMPLEMENTATION METHOD**

Before designing and designing a machine, the stages that must be carried out before designing can be seen as follows:

1. Preparation stage

The preparation stages carried out include the following:

a. Preliminary study

Preliminary studies are carried out by collecting information related to the tool to be designed through clear sources such as journals, books and so on.

- b. Identification of problems  
efficient peanut skin peeling machine .
- c. Design objectives  
Based on the problem identification, the objectives to be achieved from the design are to design a peanut skin peeling machine with a gasoline motor so that it can produce a good design and a good tool design.
2. Design Concept Planning  
In designing the design concept, the author conducted a literature study on the weight capacity of the peanut peeling machine that is usually used by peanut farmers.
3. Data collection  
In the data collection stage, the author conducts an analysis related to the design to be carried out. The data collection stage uses secondary data, which is a source of data obtained indirectly by the author through intermediary media. Secondary data in this design is obtained from other written data related to the design, such as literature, research and design journals, and other documents. The secondary data obtained as a reference are regarding the design of a peanut skin peeling machine , journals on the peanut cultivation process , and journals on processed peanut products .
4. Data processing  
The data processing stage is the stage where the raw data that has been previously obtained is processed so that results can be obtained for the machine design and design process.
5. Image Design Creation  
After the calculations are carried out to obtain the dimensions, a drawing is designed that matches the dimensions that have been obtained. This drawing design is the final result of the peanut skin peeling machine design process.
6. Preparation of tools and materials  
Prepare tools and materials for assembly
7. Machine assembly  
Once the required materials and tools are ready, assembly will be carried out according to the predetermined design drawing.
8. Testing  
After the machine is assembled, testing will be carried out. If the test fails, it will return to the data collection stage. However, if it is successful then continue with the conclusion.
9. Conclusion  
After carrying out planning calculations , testing of the planned components, data , conclusions and suggestions are obtained.

#### **4. RESULTS AND DISCUSSION**

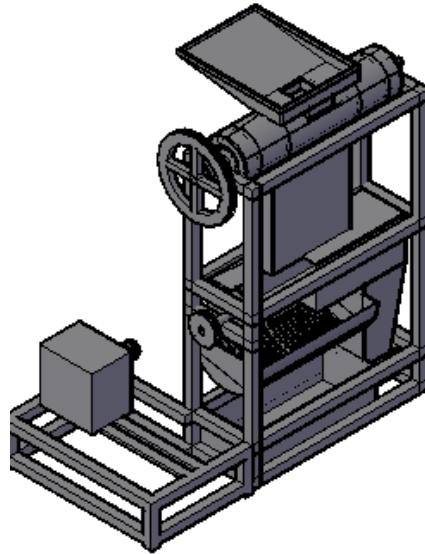

Figure 1. Peanut peeling machine

#### 4.1 Calculation of Core Components in a Machine

##### 1. Calculation of the Peeling Shaft

###### a. Axial Power

$$P = 5.5 \text{ HP}$$

$$P = 5.5 \times 0.735 \text{ kW}$$

$$P = 4.0425 \text{ Kw}$$

$$Pd = fc \times P$$

$$Pd = 1.2 \times 4.0425 \text{ kW}$$

$$Pd = 4,851 \text{ Kw}$$

###### b. Planned torsional moment

$$T = 9.74 \times 10^5 \frac{Pd}{n_2}$$

$$T = 9.74 \times 10^5 \times \frac{4,851 \text{ kW}}{500 \text{ rpm}}$$

$$T = 9.74 \times 10^5 \times 0.009702$$

$$T = 9449.748 \text{ kg.mm}$$

$$\tau_a = \frac{\sigma_b}{Sf_1 \times Sf_2}$$

$$\tau_a = \frac{37 \text{ kg/mm}^2}{6 \times 2}$$

$$\tau_a = 3.08 \text{ kg/mm}^2$$

###### c. Diameter of the peeling shaft

It is known that:

$$K_t = 1.1$$

$$C_b = 1.2$$

$$d_s = \left[ \frac{5.1}{\tau_a} K_t \times C_b \times T \right]^{1/3}$$

$$d_s = \left[ \frac{5.1}{3.08} 1.1 \times 1.2 \times 9449,748 \right]^{1/3}$$

$$d_s = [20654,4492]^{1/3}$$

$$d_s = 24.43 \text{ mm}$$

Therefore, the planned diameter of the peeling shaft is 24.43 (mm) while the diameter of the peeling shaft used is 25 (mm). Therefore, the shaft is safe to use.

#### 4.2 Shaft Calculation on Blower

##### a. Planned torsional moment

$$T = 9.74 \times 10^5 \frac{Pd}{n_1}$$

$$T = 9.74 \times 10^5 \frac{4,851 \text{ kW}}{2700 \text{ rpm}}$$

$$T = 9.74 \times 10^5 \times 0.0017$$

$$T = 1655.8 \text{ kg.mm}$$

$$\tau_a = \frac{\sigma b}{Sf_1 \times Sf_2}$$

$$\tau_a = \frac{37 \text{ kg/mm}^2}{6 \times 2}$$

$$\tau_a = 3.08 \text{ kg/mm}^2$$

**b. Blower shaft diameter**

It is known that:

$$K_t = 1.0$$

$$C_b = 1.2$$

Then the diameter of the blower shaft

$$d_s = \left[ \frac{5.1}{\tau_a} K_t \times C_b \times T \right]^{1/3}$$

$$d_s = \left[ \frac{5.1}{3.08} 1 \times 1.2 \times 1655.8 \right]^{1/3}$$

$$d_s = [3290.09]^{1/3}$$

$$d_s = 14.87 \text{ mm}$$

So, the planned diameter of the peeler shaft is 15 (mm) while the diameter of the blower shaft used is 19 (mm).

**4.3 Peeling Shaft Pulley**

Where :

D<sub>p</sub> = diameter of the peeler shaft pulley (inches)

d<sub>p</sub> = diameter of the drive pulley (2 inches = 50.80 mm)

n<sub>1</sub> = drive pulley rotation (2700 rpm)

n<sub>2</sub> = peeler pulley rotation (505 rpm)

So,

$$\frac{n_1}{n_2} = \frac{D_p}{d_p}$$

$$\frac{2700 \text{ rpm}}{505 \text{ rpm}} = \frac{D_p}{50.80 \text{ mm}}$$

$$D_p = \frac{2700 \text{ rpm} \times 50.80 \text{ mm}}{505 \text{ rpm}}$$

$$D_p = 271.60 \text{ mm}$$

So, the diameter of the peeler shaft pulley is 271.60 mm but the one sold on the market is 279.40 mm = 11 inches, so the author uses 11 inches and a pulley thickness of 55 mm.

**4.4 Blower Shaft Pulley**

D<sub>p1</sub> = diameter of the driven pulley (4 inches = 101.60 mm)

d<sub>p</sub> = diameter of the drive pulley (2 inches = 50.80 mm)

n<sub>1</sub> = drive pulley rotation (2700 rpm)

n<sub>2</sub> = blower shaft pulley rotation (rpm)

So,

$$\frac{n_1}{n_2} = \frac{D_{p1}}{d_p}$$

$$\frac{2700 \text{ rpm}}{n_2} = \frac{101.60 \text{ mm}}{50.80 \text{ mm}}$$

$$n_2 = \frac{2700 \text{ rpm} \times 50.80 \text{ mm}}{101.60 \text{ mm}}$$

$$n_2 = 1350 \text{ rpm}$$

#### 4.5. Peeling Shaft Belt

a. Distance between the pulley axles

$$C = 2 \cdot D_p$$

$$C = 2 \cdot 279.40 \text{ mm}$$

$$C = 558.8 \text{ mm}$$

b. Length of the stripper shaft belt

$$L = 2C + \frac{\pi}{2} (D_p + d_p) + \frac{1}{4C} (D_p - d_p)^2$$

$$L = 2 \cdot 558.8 + \frac{3,14}{2} (279,40 + 50,80) + \frac{1}{4 \cdot 558,8} (279,40 - 50,80)^2$$

$$L = 1117.6 + 518.41 + 23.37$$

$$L = 1659.38 \text{ mm}$$

c. The distance between the axle shafts used

$$b = 2 \times L - \pi(d_p + D_p)$$

$$b = 2 \times 1651 - 3,14(50,80 + 279,40)$$

$$b = 3302 - 1036.82$$

$$b = 2265,18 \text{ mm}$$

$$C = \frac{b + \sqrt{b^2 + 8(D_p - d_p)^2}}{8}$$

$$C = \frac{b + \sqrt{b^2 + 8(279,40 - 50,80)^2}}{8}$$

$$C = \frac{2265,18 + 2355,65}{8}$$

$$C = \frac{4659,9472}{8}$$

$$C = 577,60 \text{ mm}$$

d. Contact angle

$$\theta = 180^\circ - \frac{57(D_p - d_p)}{C}$$

$$\theta = 180^\circ - \frac{57(279,4 - 50,8)}{558,8}$$

$$\theta = 180^\circ - 23,31$$

$$\theta = 156,69^\circ$$

#### 4.6. Belt on the Blower

a. Blower axle distance (C)

$$C = 2 \cdot D_{p1}$$

$$C = 2 \cdot 101.6 \text{ mm}$$

$$C = 203.2 \text{ mm}$$

b. Length of blower shaft belt

$$L = 2C + \frac{\pi}{2} (d_p + D_{p1}) + \frac{1}{4C} (D_{p1} - d_p)^2$$

$$L = 2 \cdot 203.2 + \frac{3,14}{2} (50,8 + 101,6) + \frac{1}{4 \times 203,2} (101,6 - 50,8)^2$$

$$L = 406.4 + 239.268 + 9.525$$

$$L = 655.193 \text{ mm}$$

c. The axle distance used

$$b = 2 \times L - \pi(d_1 + d_2)$$

$$b = 2 \times 635 - 3,14(50,8 + 101,6)$$

$$b = 1270 - 478.53$$

$$b = 791,47 \text{ mm}$$

$$C = \frac{b + \sqrt{b^2 + 8(d_2 - d_1)^2}}{8}$$
$$C = \frac{b + \sqrt{791,47^2 + 8(101,6 - 50,80)^2}}{8}$$
$$C = \frac{791,47 + 755,26}{8}$$
$$C = 193,34\text{mm}$$

d. Contact angle

$$\theta = 180^\circ - \frac{57(Dp_1 - dp)}{C}$$
$$\theta = 180^\circ - \frac{57(101,6 - 50,8)}{203,2}$$
$$\theta = 180^\circ - 14,25$$
$$\theta = 165,75^\circ$$

#### 4.7. Bearings

The diameter of the peeling shaft used is 25 mm, so from the standard bearing table (Sularso and Kiyokatsu Suga table, basis for planning and selecting machine elements 2018, p. 143) the following data is obtained :

1. Bearing number = 6005
2. Inner diameter (d) = 25 mm
3. Outer diameter (D) = 47 mm
4. Bearing width (B) = 12 mm
5. Radius (r) = 1 mm
6. Specific dynamic nominal capacity (C) = 790 kg
7. Specific static nominal capacity (Co) = 530 kg

#### 4.8 Creation

The manufacturing process for this peanut peeling machine is as follows:

1. Make a frame according to the picture.
2. Cut the L-shaped steel according to the design size using a cutting grinder.
3. Then weld the L-shaped steel at each joint according to the picture.
4. then the frame is finished and looks like the picture.
5. Install the motor and peeler along with the bowler on the frame.
6. Then the bearing housing is installed on the machine frame according to the picture.
7. Also install the pulleys and belts to transmit the petrol motor power to the peeler and bowler.
8. Then adjust the belt tension and then lock the petrol engine mounting bolts.
9. Then install the inlet funnel and outlet funnel using bolts.

#### 4.9 Operation and Maintenance

##### 4.9.1 How the Machine Works

How the peanut peeling machine works:

1. Provide the materials to be processed, namely peanuts, as well as the equipment that will be needed during the machining process;
2. Start the gasoline engine by opening the fuel tap on the carburetor so that the fuel in the fuel tank flows into the carburetor then Close the carburetor choke by sliding the choke lever back After that, press the switch button to the ON position Then hold the pull handle

and pull the recoil starter firmly. After the engine starts, immediately reopen the choke that was closed previously.

3. Once the motor reaches normal (stable) rotation, start putting the peanuts into the inlet funnel, then the rotating knife will hit the peanuts until the peanut skin is peeled and the peanut kernels are separated from the peanut skin.
4. Do this step until the results obtained are according to your needs.

#### **4.9.2 Machine Maintenance and Repair**

To achieve maximum production volume, it is necessary to ensure that the machine used is as ready as possible, so that the machine is ready and does not experience any disruptions during production.

This maintenance is defined as an activity that aims to maintain and safeguard each machine component so that it lasts a long time and can achieve maximum production results.

The main objectives of the care system are:

- 1) So that the machine used is in optimal ready-to-use condition to ensure the smooth running of the machine's work process.
- 2) To extend the service life of the machine.
- 3) To ensure operator safety in operating the machine.
- 4) To detect engine damage as early as possible so that fatal damage can be prevented.

Treatment can be divided into two, namely:

##### **a. Preventive Maintenance**

Preventive maintenance is a type of maintenance performed internally to prevent potential engine malfunctions or breakdowns. Examples of this type of maintenance include inspections, adjustments, and lubrication.

##### **b. Corrective Maintenance**

Corrective maintenance is a type of maintenance that aims to restore a machine to its required standard. This includes repairs and disassembly.

## **5. CONCLUSION**

After carrying out planning calculations on the planned components, the following data was obtained:

1. Gasoline engine used = 5.5 Mobile phone
2. Bearing = 6005
3. Belt length to peeler = 65 inch
4. Belt length to blower = 25 inch
5. Diameter pulley blower = 4 inch
6. Pulley diameter peeler = 11 inch
7. Diameter pulley driver = 2 inch

After analyzing the production/manufacturing costs of this machine, the price for manufacturing 1 peanut skin peeling machine was Rp. 4,019,372.24.

Based on the tests and experiments that have been carried out, the author suggests several things to all parties who use and develop this peanut skin peeling machine as follows:

1. Moving the machine is still difficult, so it requires wheels on the frame legs machine.
2. Replacement of components is carried out after the service life has been reached according to the established limits. determined.
3. Perform maintenance and inspection  
periodic maintenance and repairs, for example by providing lubricant to the bearings and shafts so that shaft wear can be reduced.

## **6. BIBLIOGRAPHY**

- Rahmianna, Agustina Asri, Herdina Pratiwi, and Didik Harnowo. 2015. *Peanut Cultivation* . Indonesian Agricultural Research Institute, 133-16.
- Sato, Takeshi and N. Sugianto. 1986. *Machine Drawing According to ISO Standards* . Jakarta: Paradnya Paramita.
- Suga, Kiyokatsu, and Sularso. 2004. *Basics of Machine Element Planning and Selection* . Jakarta: PT Pradnya Paramita.
- Trustina. 2015. *Morphology and Growth of Peanuts* . Agricultural Research Institute, 40 – 59.